

PA2204A

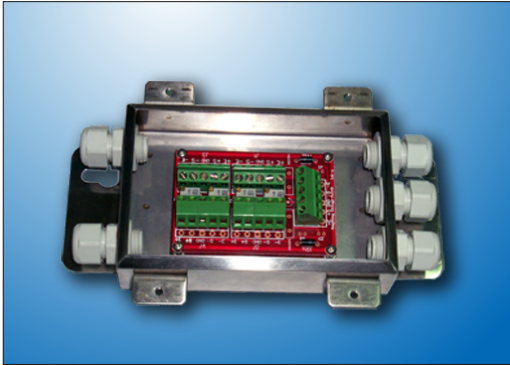

Compensatory Junction Box

Hardware Characteristics

- * Stainless steel case
- * Tight sealing joints
- * Multi-coil adjustable resistance
- * Water-proof sealing

Functionality

- * Signal summing for multiple transducers
- * Cable joint for multiple transducers
- * Balance adjustment for electronic scales

Inside layout and explanation

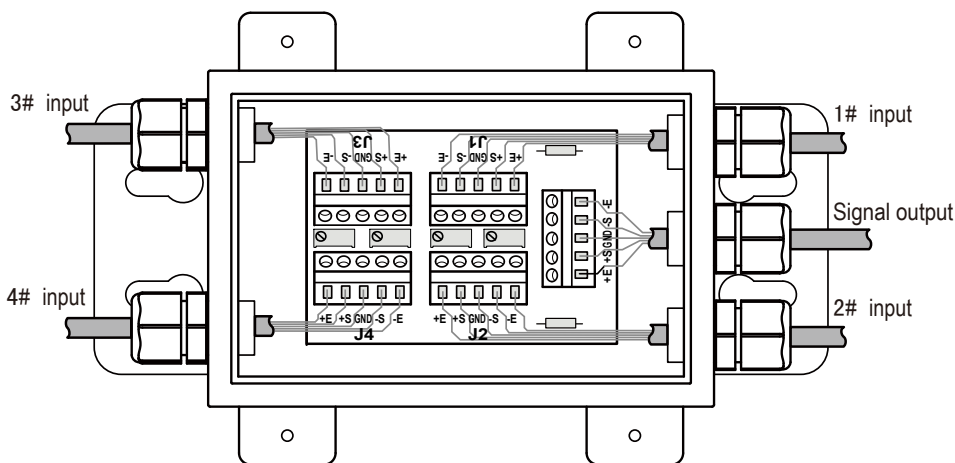

Terminal	Explanation
+ E	Bridge resistance plus (+)
+ S	Transducer signal plus (+)
GND	Ground shielding
- E	Bridge resistance minus (-)
- S	Transducer signal minus (-)

Case and dimension

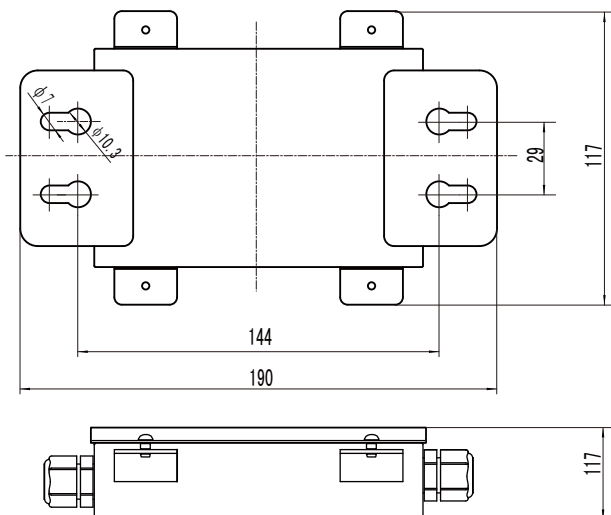

- 1.Measurement: mm
- 2.Water-proof joint model: PG9